

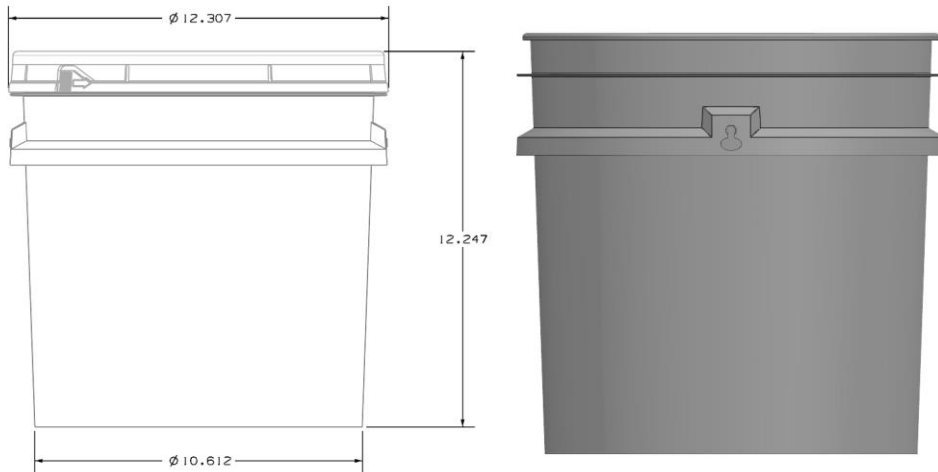

PolyPailTM Inc.

4.25-GALLON PAIL



SPECIFICATIONS:

| | |
|----------------------------|---------|
| Height..... | 12.035" |
| Outer Diameter at top..... | 12.307" |
| Bottom Diameter..... | 10.612" |
| Thickness..... | 90 mil |

53' TRUCKLOAD QUATITIES:

| | |
|-----------------------------|-------------------|
| 120 pail count bundles..... | 6240 pails & lids |
| 132 pail count bundles..... | 6600 pails & lids |

User Guidelines: End users must ultimately make their own determination as to the suitability or compatibility of our products for his or her intended use and compliance status of the final product before using. Tests including but not limited to expected fill volume, hot fill compatibility, individual stacking procedures and compatibility with end user production equipment should be completed and verified by end user prior to purchase.

This is general sales information only. Measurements are all approximates, sizes and dimensions contained in the specifications may vary. PolyPail reserves the right to make modifications to any specifications without notice.

**Made from FDA
Approved, 100%
Prime Virgin HDPE**

**Available in
Bundle Quantities
of 120 or 132**

**Available with All
Plastic or Metal
Handles**

Colors Available

**Same Lids as the
5-Gallon Pails**

POLYPAIL, INC.

1615 Grebby St. Ste A
P.O. Box 444
Delavan, WI 53115

Phone: 262-725-7575
Fax: 262-725-7577

sales@polypail.com

